

MAINTENANCE

The lenses have anti-reflective coating and are dirt resistant. However, they are not scratch-proof. Use only cleaning agents intended for optics. Larger impurities should be removed first with compressed air or with a clean soft brush.

WARNINGS

The lens is equipped with a rubber seals to protect the interior from dust and moisture. It is not, however, completely waterproof. Do not submerge it in water or store it for extended periods of time in humid places. To achieve better water-tightness, use of the front protective filter is recommended.

Protect the lens from shock, being dropped and excessive vibration, and do not leave the lens in direct sunlight as a focused light beam may cause a fire.

Do not expose the lens to high temperatures.

Do not look through the lens at the sun or in its general direction, as that may cause permanent eye damage.

The lens and its accessories should be kept away from children and animals, as they contain small elements that constitute a choking hazard.

Unsupervised dismantling of the lens may lead to permanent damage and loss of warranty.

In the case of any faulty operation, it is strongly recommended that you contact the authorized Irix service point.



TH Swiss AG
Switzerland
info@irixlens.com
irixlens.com



[IRIX]

cine lens
11mm T4.3

USER'S MANUAL
ENG

Thank you for choosing our product. Your new lens has been designed with both the effort and experience of not only engineers, but also of cinematographers. It has been created based on the best available materials, technology and solutions, thus making it the perfect tool for both professionals and hobbyists.

The Irix Cine 11mm T3.0 Macro 1:1 is a full frame wide-angle cinema lens designed for cameras with sensor diagonal size up to 43.3 mm.

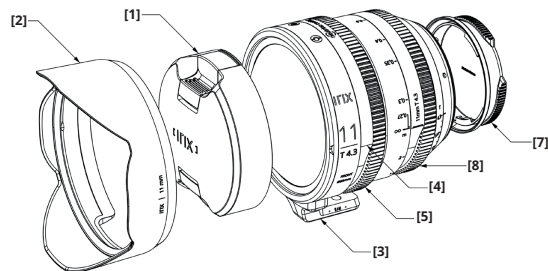

[1] FRONT LENS CAP

The front lens cap protects the front lens and should always be put in place whenever the lens is not being used.

[2] LENS HOOD

Using the lens hood improves contrast and protects the front lens against dirt and mechanical damage.

The lens hood has an easy to use magnetic mount with a positioning system.

WARNINGS

Do not hold the lens by the lens hood, as this may cause the lens hood to detach and cause the lens to fall.

[3] LENS SUPPORT FOOT

The support foot is a standard feature of the Irix Cine 11mm T4.3 lens.

The lens is equipped with a detachable foot for supporting the lens when using follow focus system on rods. Depending on the follow focus configuration, the foot can be attached at the bottom or top position of the lens.

WARNINGS

The foot is not suitable for mounting a camera with the lens directly on a tripod. Using it to attach the lens to the tripod may lead to damage both the lens and a camera.

[4] ADAPTING RING FOR FOLLOW FOCUS SYSTEM

The lens is equipped with a unique rotating adaptive ring for follow focus systems. It provides an easier fit for your focus gear, to the focus ring from any angle. The ring can be rotated 360° with increments of 15 degrees.

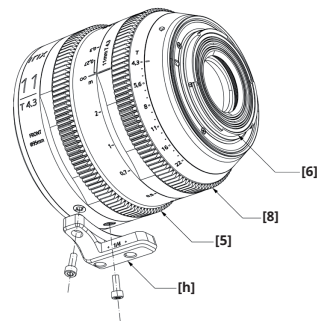

[5] FOCUS RING

To focus on a given object, look at the image in the viewfinder or on the camera screen and adjust it manually by rotating the focus ring. You can also use the distance scale on the lens body to estimate the distance to the chosen object for the photograph.

The focus ring can be rotated by hand or by using the follow focus system in the range of 0,27m (10.63") to infinity.

[6] LENS MOUNT

Mounting the lens to the camera as described in the camera's user manual may differ with various systems.

The marker (dot) on the lens body facilitates mounting the lens onto the camera.

[7] REAR LENS CAP

The rear lens cap protects the lens during transport and should be put in place whenever the lens is not attached to the camera.

[8] APERTURE RING

The aperture ring allows for smooth adjustment of the T number of the lens in the range from T4.3 to T22. The ring can be rotated by hand or by using the follow focus system.

[9] TECHNICAL SPECIFICATION

Image coverage	full frame (43.3mm)	
Focal length	11mm	
Aperture range (T)	T4.3 - T22	
Number of iris blades	9 (rounded shape)	
Minimum focusing distance	0,27 m (10.63")	
Focus ring	rotation angle	180°
	gear pitch	0.8 M
	number of teeth	117
	distance scale	metric / imperial
Aperture ring	rotation angle	75°
	gear pitch	0.8 M
	number of teeth	110
Viewing angle (horizontal)	full frame	117°
	S-35mm 1.39x	99,3°
	APS-C 1.53x	93,8°
	APS-C 1.62x	90,6°
	MFT 2.0x	78,6°
Front filter thread	N/A	
Weather sealing	Yes	
Front diameter	95 mm	
Dimensions (L x D) ¹	Canon EF - mount	105 x 95 mm
	Sony E mount	131 x 95 mm
	Arri PL mount	104 x 95 mm
	MFT mount	129 x 95 mm
Weight ²	Canon EF - mount	1105g
	Sony E mount	1170g
	Arri PL mount	1130g
	MFT mount	1160g
Included accessories	lens hood	1 pc
	front lens cap	1 pc
	rear lens cap	1 pc
	support foot 1/4"	1 pc

1, 2 - a lens without accessories